

International Marine Ingredients Conference, September 22nd – 24th, Oslo, Norway

Production of high quality herring oil

Ana Carvajal

Research manager

SINTEF Fisheries and Aquaculture

Outline

- Herring rest raw materials – a fish oil and protein source for human consumption?
- Production of oil and protein for human consumption
- Composition and quality of the oil
- Use of antioxidants during processing of herring rest raw materials
- Conclusions



Need for new omega-3 sources and more valuable utilization of the raw material

Bimbo, A. (2013):

**ESTIMATED SALES OF OMEGA 3 PRODUCTS ALL CATEGORIES
VS. CRUDE FISH OIL NEEDED**

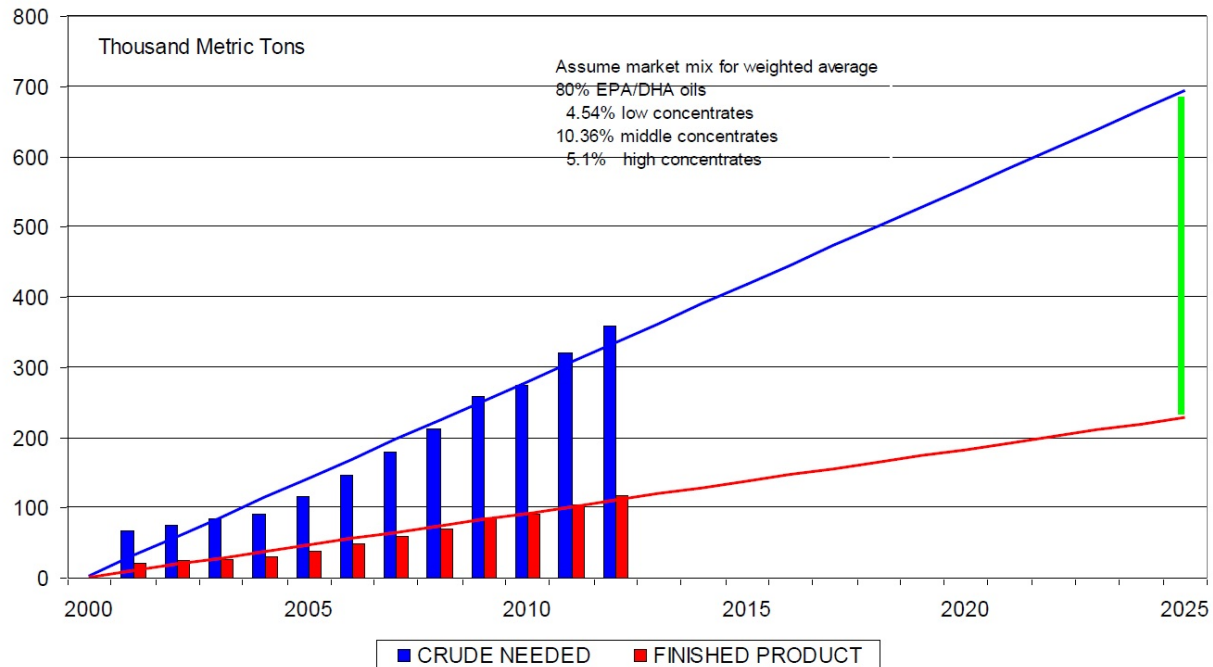

Estimated sales of omega-3 products (EPA/DHA oils, low concentrates, middle concentrates and high concentrates) for 2013-2025

Herring rest raw materials – a source of omega-3 and protein for human consumption?



- In 2012, 229 000 T of rest raw materials were generated from the Norwegian herring and mackerel industry^(*)
- As much as 98 % of the herring rest raw materials are currently being used
- But...
 - they are mainly used for production of silage (preservation with formic acid) or ordinary fish oil and fish meal for animal and fish feed.
- Filleting factories receive herring of **food grade quality**
- By treating the rest raw materials in the same way, they can be used to make products for human consumption

^(*) Olafsen, T., Richardsen, R., Nystøyl, R., Strandheim, G. and Kosmo, J. P. (2012). *Analyse av marint restråstoff*, 2012, FHF.

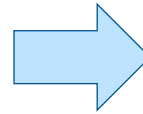
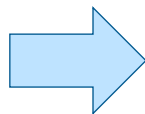

3 900 T n-3 lipids



29 770 T lipids

~ 43 million people could get their daily recommended intake (250 mg (EFSA)) for a whole year around

Herring rest raw materials
229 000 T

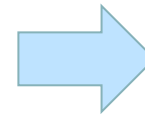
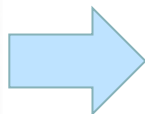

~ 2.35 mill people could get their daily recommended intake for a whole year around

34 350 T proteins

Aim

➤ ***Produce high quality oil and protein from Norwegian spring spawning herring rest raw material***

- 1) Carry out the studies on a semi-industrial scale by using a mobile production plant in order to achieve a more easy knowledge transfer from research to industrial implementation.
- 2) Study the effect of production method on the composition and quality of the oil and proteins
- 3) Study the effect of addition of antioxidants to the rest raw material before processing



Mobile SeaLab – a mobile pilot plant for production of fish oil and fish protein hydrolysate



- Mobile factory – easily shipped to the wanted location
- Easy to modify to give various process configurations



Production capacities:

- Thermal treatment :
1000 kg of by-products/hour
- Enzymatic hydrolysis:
400 kg of by-products/hour

Thermal treatment

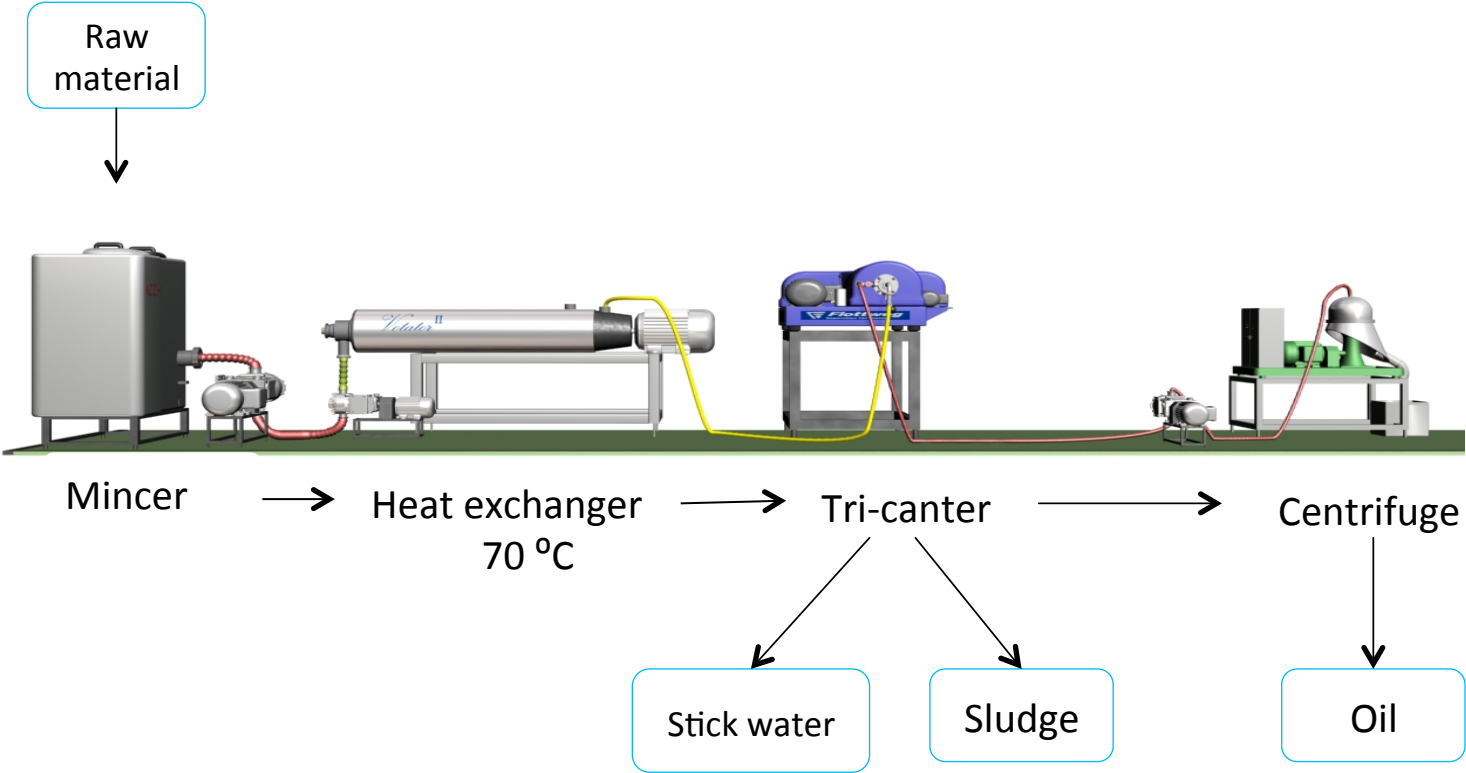

Enzymatic hydrolysis

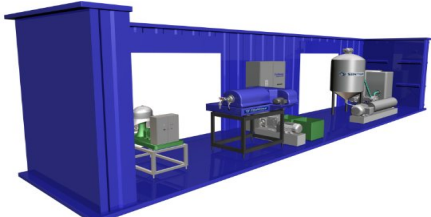

Hydrolysis tank :
1:1 by-products:water
Enzyme (Papain:Bromelain (1:1),
0.1 wt% of by-products)
Hydrolysis time: 1 h

Inactivation: 90 °C, 10 min

Raw material

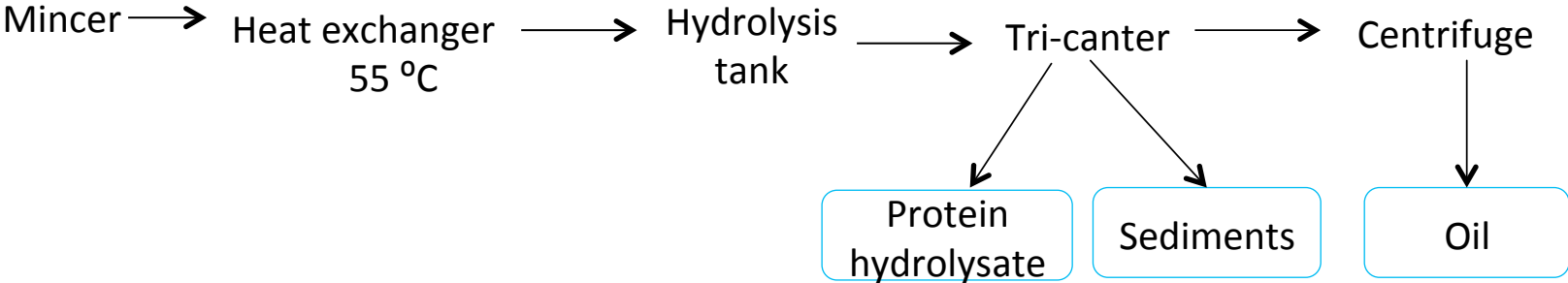
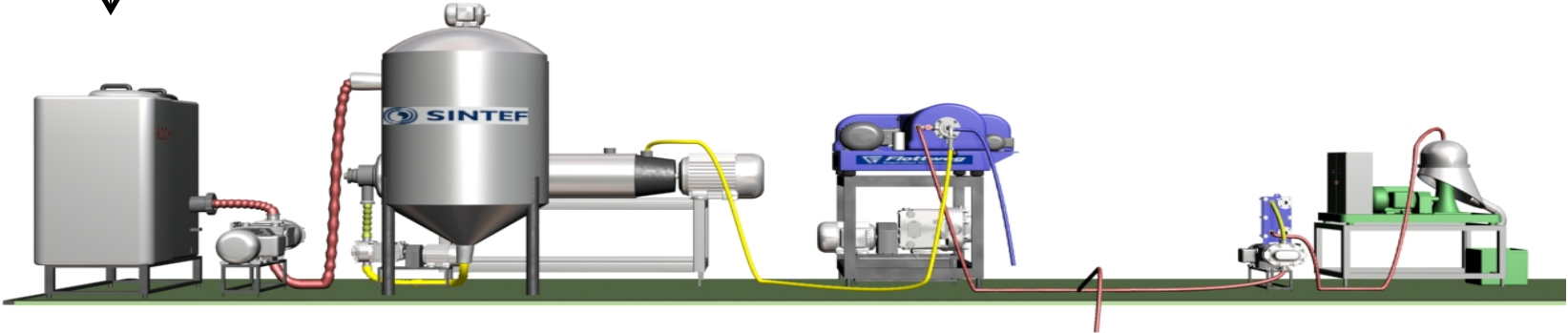

High quality herring oil



- Mainly triglycerides, 98.5 – 99.7 %
- Low content of free fatty acids (%FFA) < 0.4 %

-> **good quality rest raw material**

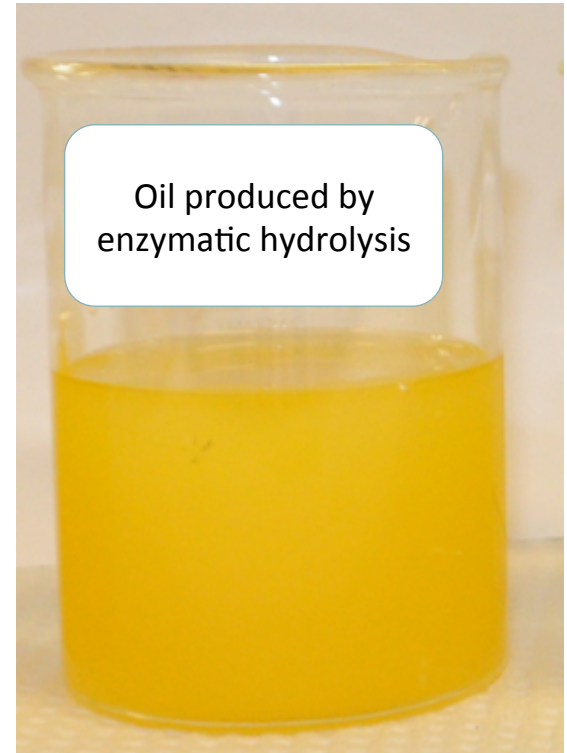

Thermal treatment:

- MUFAs (18:1 n-9, 20:1 n-9, and 22:1 n-11)
– **main components > 55 %**
- 10 – 15 % LC-PUFAs
(February-November)

Enzymatic hydrolysis:

- MUFAs (18:1 n-9, 20:1 n-9, and 22:1 n-11)
– **main components > 55 %**
- 13 – 16 % LC-PUFAs
(February - November)

High quality herring oil from fresh rest raw materials



	Crude oil (thermal treatment)	Crude oil (enzymatic hydrolysis)	Commercial crude oils*	Silage	GOED (refined oils)
FFA	0.2 %	0.4 %	1 – 7	8 -10	
PV	1.9 ± 0.3	2.5 ± 0.4	3 – 20		5
AV	0.7 ± 0.2	1.1 ± 0.1	4 – 60		20
TOTOX	4.5	6.1	10 – 60	20 – 25	30
Oil stability (OSI/ Rancimat)	54.4	20.7	13.6**		

FFA – free fatty acids, %

PV – peroxide value, meq peroxide/kg oil

AV- anisidin value

Totox = PV x 2 + AV

OSI was measured at 70°C

GOED – Global Organization for EPA and DHA

* In *Long chain omega-3 oils*, H, Breivik, 2007

**salmon oil, earlier studies

Addition of antioxidant to herring rest raw materials



Aim

Study the effect of addition of antioxidants to herring rest raw material prior to processing

See if the addition of antioxidants can give an oil with lower oxidation status and higher stability

- Use a screening method to find the best suitable antioxidants for retaining oxidation in herring rest raw material
- Study the effect of the antioxidants by performing trials in the mobile production plant

Using oxygen uptake rate to study oxidation in herring rest raw material

polyunsaturated fatty acids
 \downarrow O_2 ← Oxygen uptake rate quantification

Lipid hydroperoxides (LOOH) [PV]

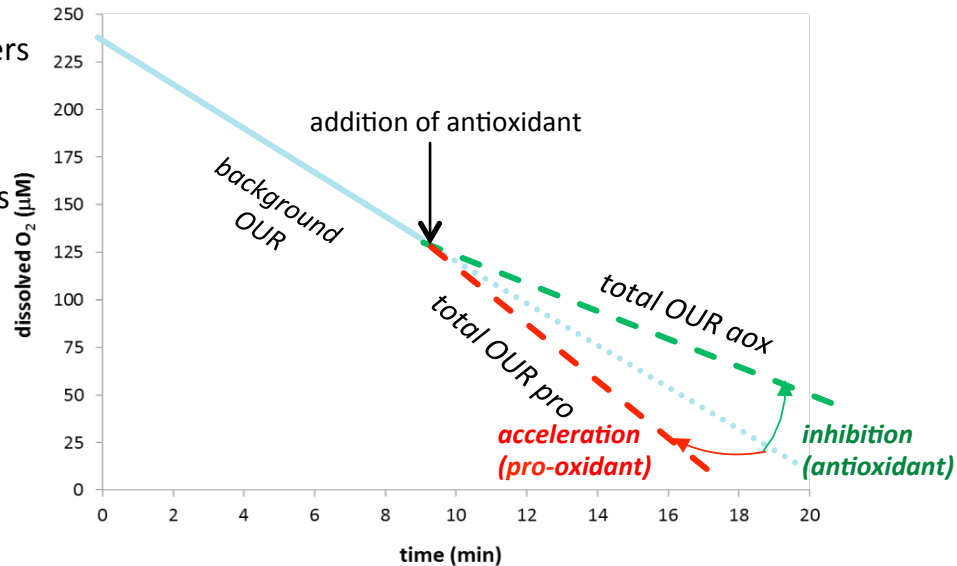
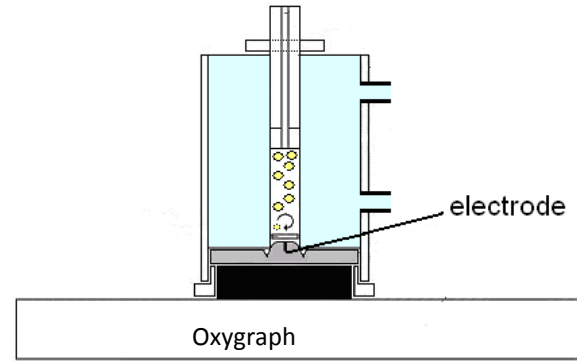
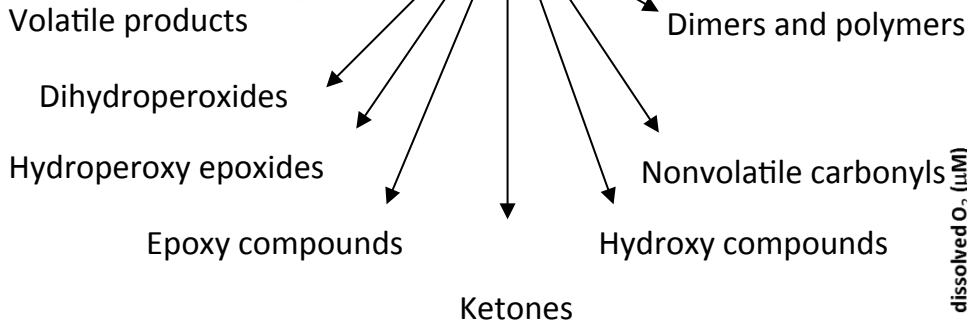

$$\% \text{ inhibition or acceleration} = 100 - \frac{\text{total OUR aox}}{\text{background OUR}} \times 100$$

SINTEF Fisheries and Aquaculture

Model system for screening of different antioxidants

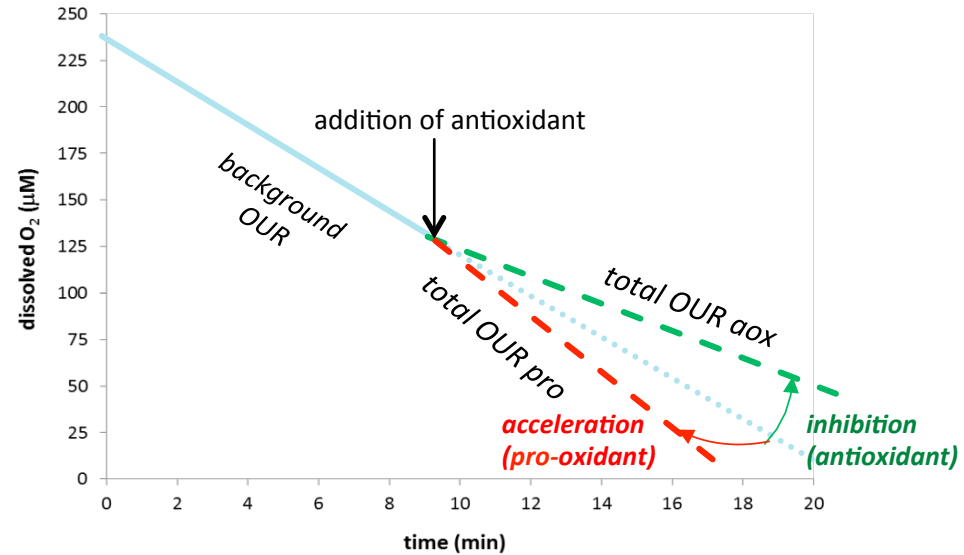
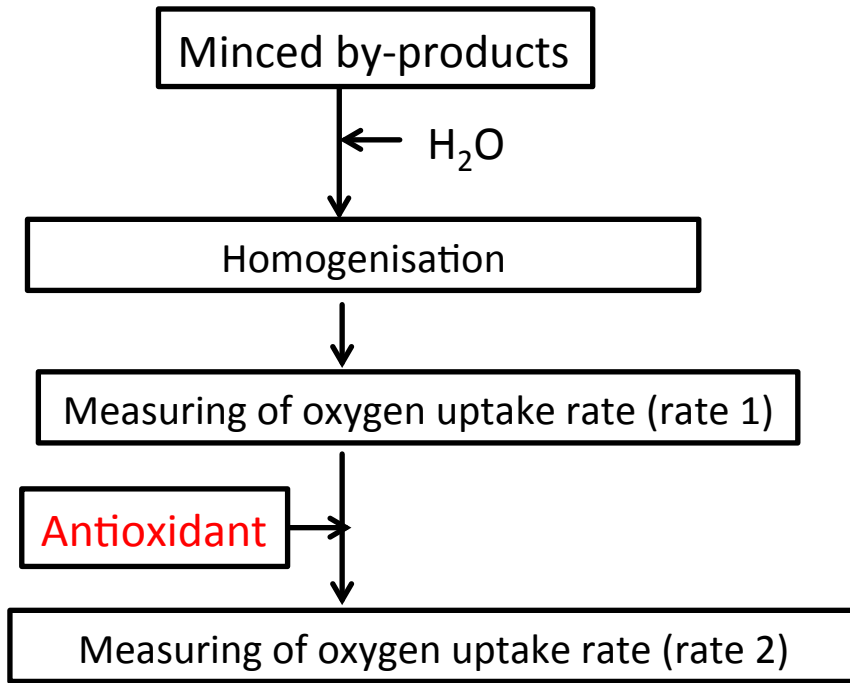

% inhibition or acceleration = $100 - \frac{\text{total OUR aox}}{\text{background OUR}} \times 100$

Effect of different antioxidants on the inhibition of oxidation of herring rest raw materials

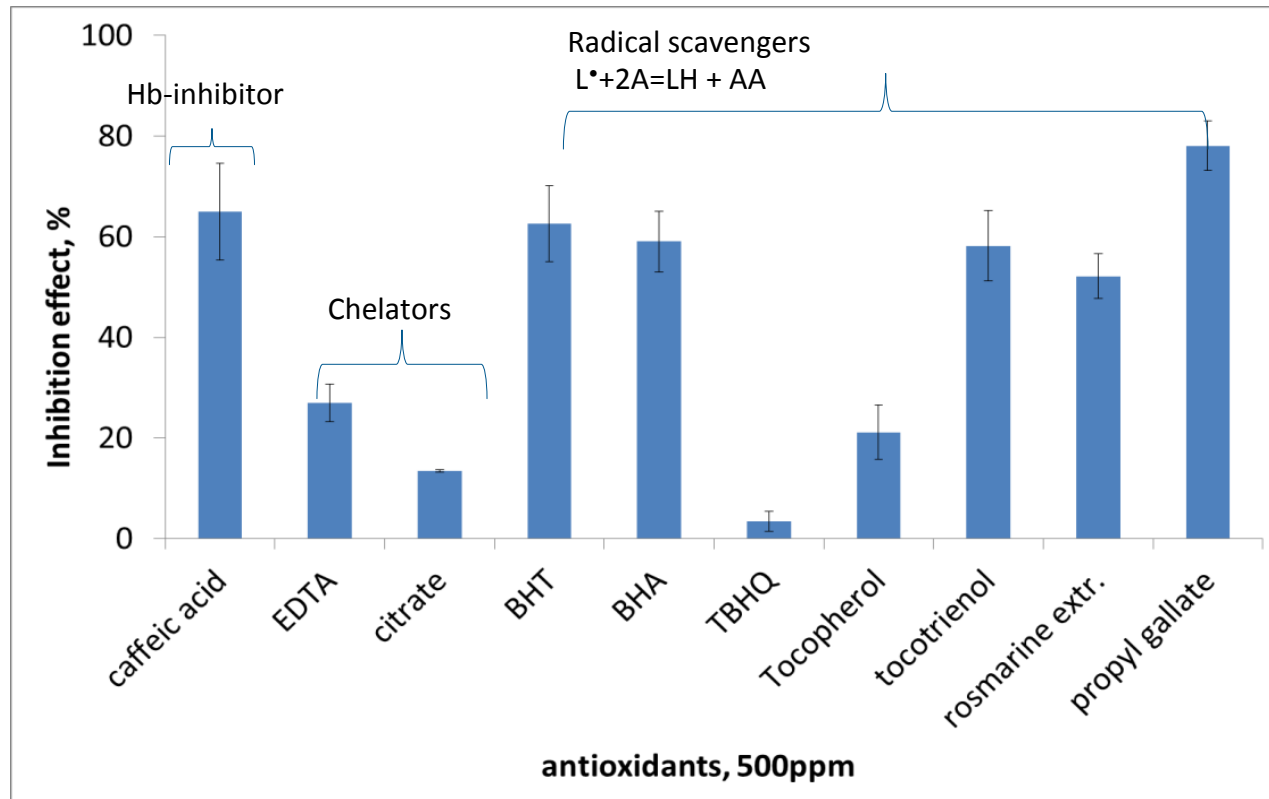

Three antioxidants, [BHT](#), [propyl gallate](#) and [citrate](#), were chosen for further testing in the pilot plant

Thermal treatment

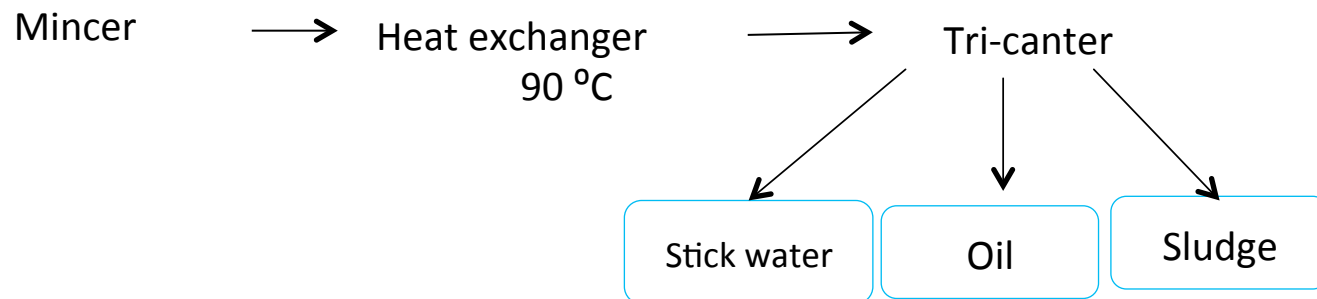
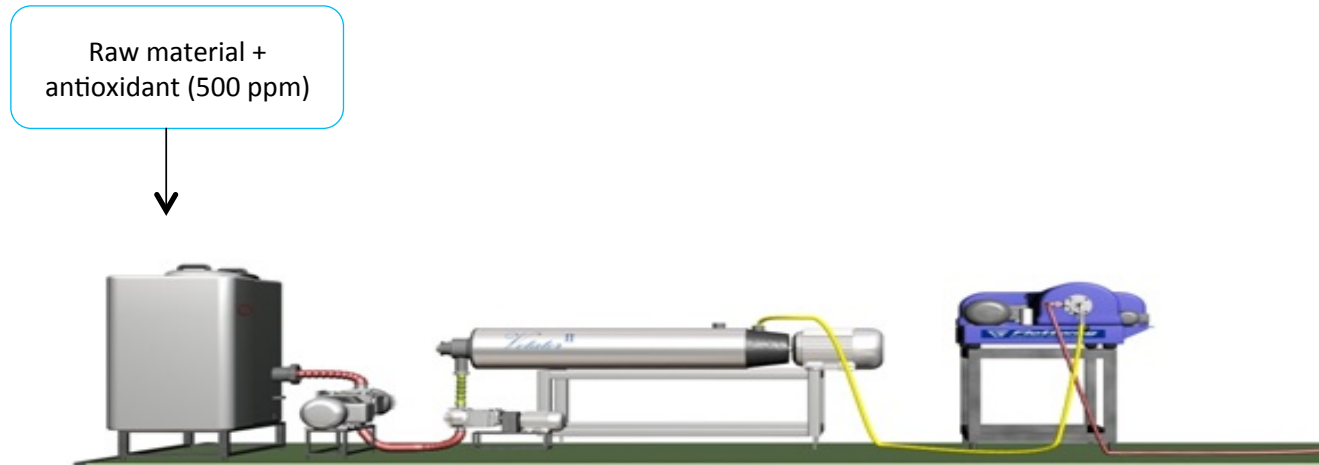
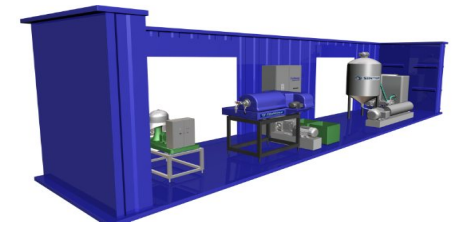

Enzymatic hydrolysis

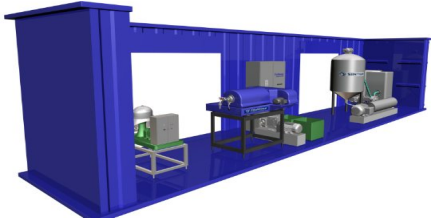

Hydrolysis tank :
1:1 by-products:water
Enzyme (Papain:Bromelain (1:1),
0.1 wt% of by-products)

Hydrolysis time: 1 hour
Inactivation: 90 °C, 10 min

Raw material +
antioxidant (500 ppm)

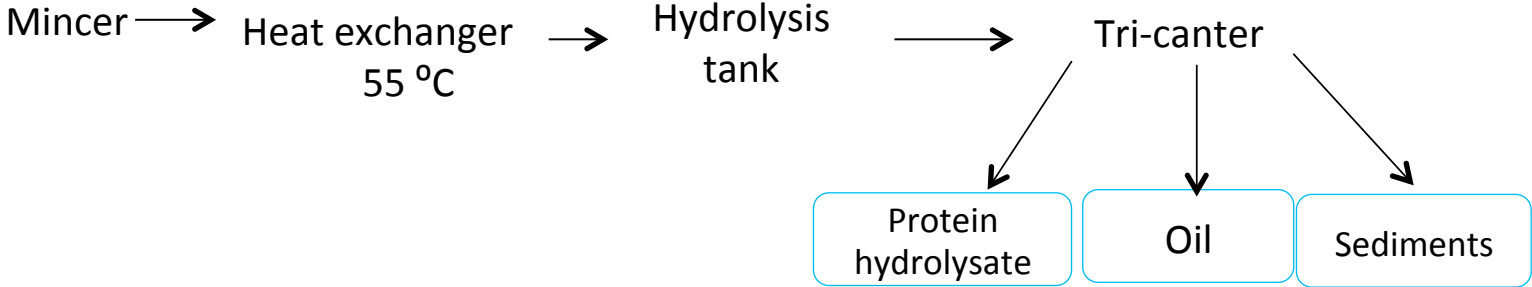

High quality herring oil from fresh rest raw material



	PV		AV		TOTOX	
		% I		% I		% I
<i>Thermal treatment (90 °C)</i>						
Crude oil without AO	2.6 ± 0.3		1.3 ± 0.1		6.6	
Crude oil with BHT	1.4 ± 0.3	46 %	1.1 ± 0.1	15 %	3.9	40 %
Crude oil with PG	0.7 ± 0.3	73 %	0.6 ± 0.1	53 %	1.9	71 %
Crude oil with CA	2.1 ± 0.3	19 %	2.1 ± 0.1	- 61 %	6.4	4 %
<i>Enzymatic hydrolysis (55 °C)</i>						
Crude oil without AO	3.1 ± 0.3		1.5 ± 0.1		7.6	
Crude oil with BHT	0.6 ± 0.3	81 %	0.5 ± 0.1	33 %	1.7	78 %

Conclusions



- Herring rest raw materials can be used to produce high quality oil
- The use of the rest raw materials within a short time after filleting gives an oil with low amount of FFA, low oxidation status and high stability.
- Antioxidants was added to the rest raw material prior to oil production to see if it was possible to slow oxidation during processing
- Analysis shows that by adding antioxidants to the rest raw material one can produce an oil with even lower oxidation status and higher stability

Acknowledgements



Funding :

- "HerringOmega3" (NRC, EPAX)
- "Gold from the silver of the sea" (Department of Foreign Offices)

Co-workers and others:

- Bio-processing group at SINTEF Fisheries and Aquaculture
- EPAX
- Grøntvedt Pelagic

Thank you for your attention!